

R 1103

Designation : swivel fitting,
non-fluch countersunk head, Ø50 mm

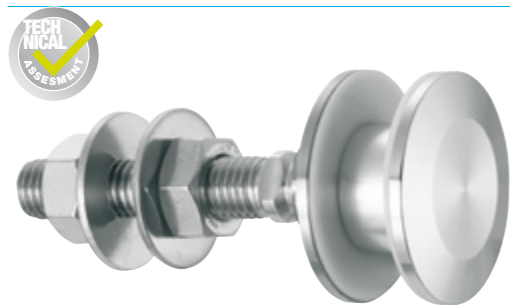

Patent No: 9806556
Technical assessment available online: www.sadev.com
Sealing strip between glazing available p.8.26

REFERENCE TO ORDER			
GLASS THICKNESS	Ø AXIS	LENGTH AXIS (mm)	ARTICLE CODE
8 ≤ V ≤ 15	M14	65	R1103-0815-1465*
15 < V ≤ 22	M14	65	R1103-1522-1465
22 < V ≤ 26	M14	65	R1103-2226-1465
SPECIAL	SPECIAL	SPECIAL	R1103-V-SP

* R1103-0815-1465 : Model - Glass thickness - Type axis and length.

Dimensions

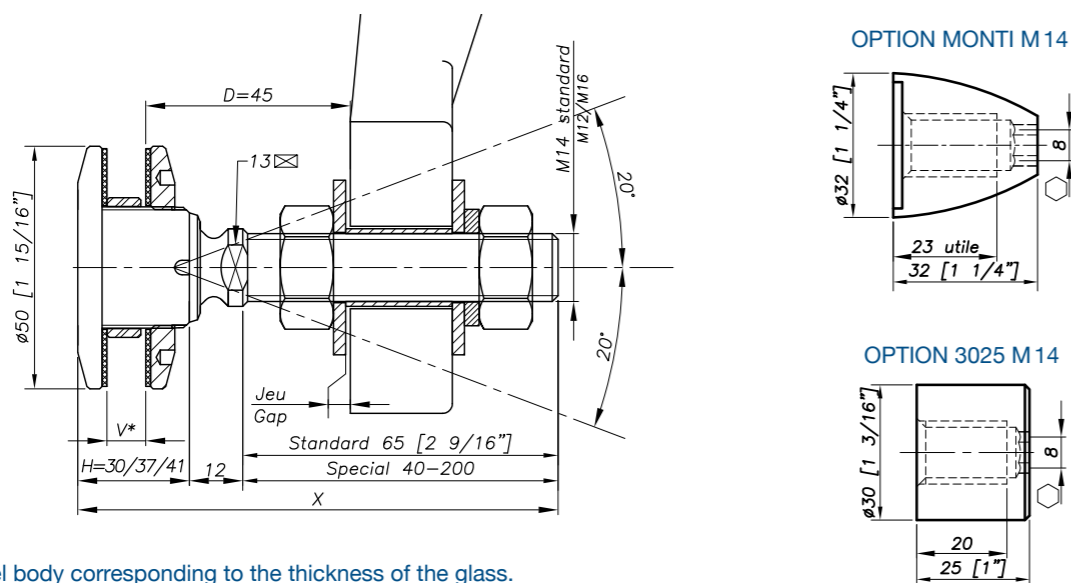

H = Swivel body corresponding to the thickness of the glass.
V* = glass thickness

Glass drilling

MONOLITHIC GLASS

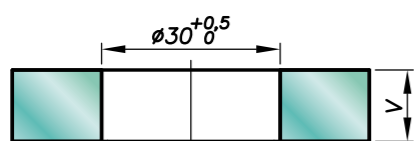

LAMINATED GLASS

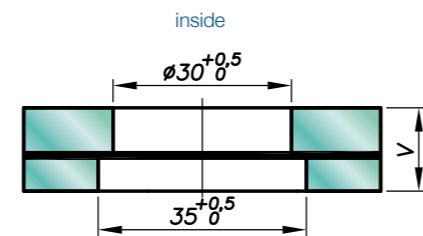

V = 1st glass + intercalated films + 2nd glass

Available for glass thicknesses from 8 to 31.52 mm, for other thicknesses please consult us.

It is important to provide the following information with each request: the glass composition (ex.: 10 mm monolithic, 8.8.4 laminated, 8.8.2-12-10 insulating) / the length and diameter of the threaded axle if not standard dimensions (M14, 65 mm) / the reference of the spider to be used as support, or the thickness of an existing support for the delivery of the spacer.

R 1103

Mechanical performance

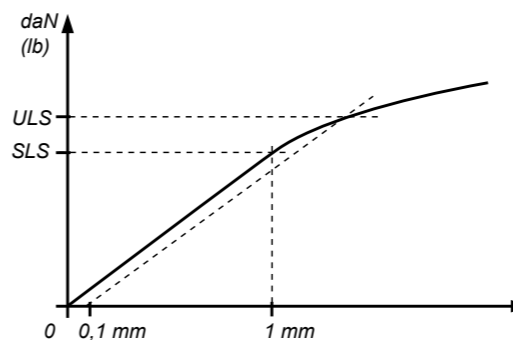

	BENDING CAPACITY			PULL OUT CAPACITY
	D	SLS*	ULS*	ULS*
M 14	45mm	344 daN (773 lb)	577 daN (1297 lb)	1 400 daN (3147 lb)
	60mm	153 daN (343 lb)	364 daN (818 lb)	
M16	45mm	504 daN (1133 lb)	827 daN (1859 lb)	
	60mm	253 daN (568 lb)	525 daN (1180 lb)	

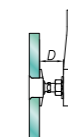

*SLS - Serviceability Limit State: load at 1mm deformation
*ULS = Ultimate Limit State: load at the elastic limit (Rp0.1).
Values are given without factor of safety.
Tests available online: www.sadev.com

Components

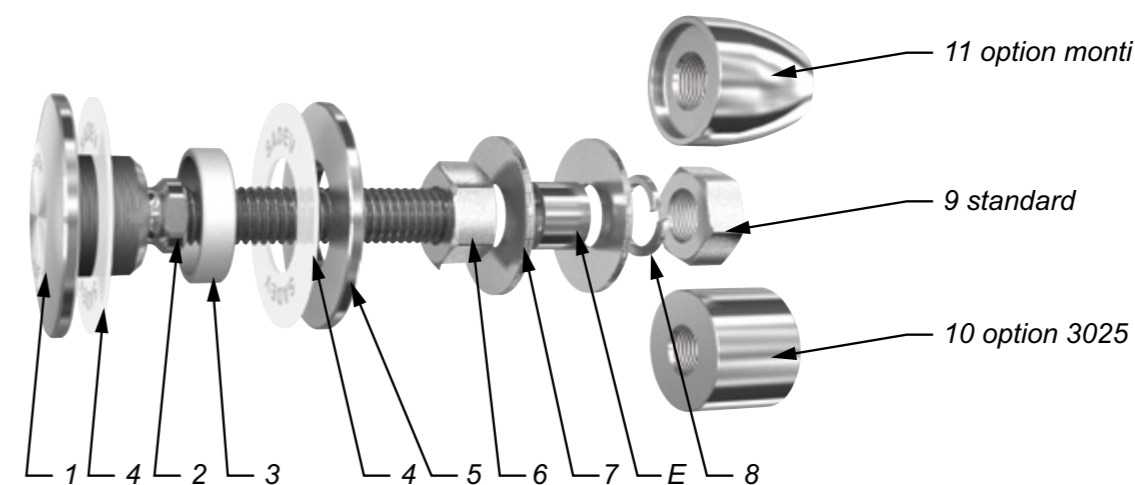

MARK	QUANTITY	DESIGNATION	MATERIAL
1	1	Swivel body	X2 Cr Ni Mo 17.12.2 as per EN 10088-3
2	1	Threaded Axle	X4 Cr Ni Mo 16.5.1 as per EN 10088-3
3	1	Glass hole grommet	AW-1050A as per EN 573-3/AI 99.5%
4	2	Contact washer	White polyacetyl/white polyethylene
5	1	Glass nut Ø50	X2 Cr Ni Mo 17.12.2 as per EN 10088-3
6	1	Nut DIN 934	A4
7	2	Washer	A4
8	1	Lock washer DIN127	A4
9	1	Nut DIN 934	A4
10	1	3025 Cap nut - Option	X2 Cr Ni Mo 17.12.2 as per EN 10088-3
11	1	Monti cap nut - Option	X2 Cr Ni Mo 17.12.2 as per EN 10088-3

Suggested mounting instruction

Insert parts N° 1/2, 4, and 3 into the glass hole.

Mount the second contact washer N° 4 and glass nut N° 5 and tighten to 20Nm (15 ft-lb) for monolithic glass and 10Nm (7.5 ft-lb) for laminated glass using tools SADEV ref. 097581160.

Mount nut N° 6 and washer N° 7 onto parts N° 1/2.

Insert the threaded axle into the support with spacer E (available on request), see technical page. Adjust the depth. Mount washer N° 7, lock washer N° 8, and nut N° 9 and tighten to 60Nm (45 ft-lb) using a 22 mm wrench.

SADEV recommends using thread locking compound whenever possible.