

# R 1001 LC

Designation : swivel fitting



REFERENCE TO ORDER			
GLASS THICKNESS	Ø AXIS	LENGTH AXIS (mm)	ARTICLE CODE
8 ≤ V ≤ 14	M12	50	R1001LC-01
14 < V ≤ 18	M12	50	R1001LC-02
SPECIAL	SPECIAL	SPECIAL	R1001LC-SP

Patent No: 9806556  
Sealing strip between glazing available p.8.26

## Dimensions

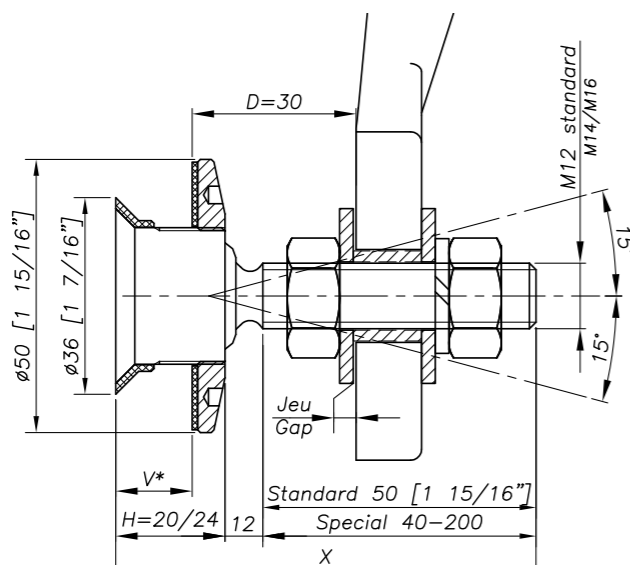

H = Swivel body corresponding to the thickness of the glass.  
V\* = glass thickness

## Glass drilling

### MONOLITHIC GLASS

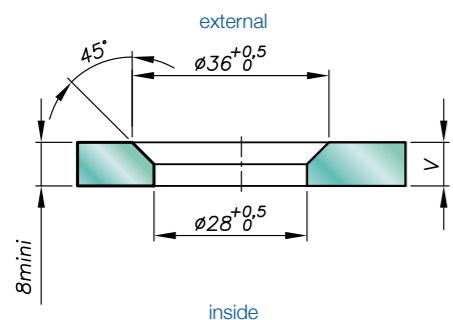

### LAMINATED GLASS

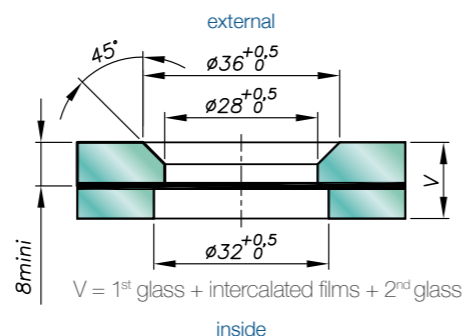

Available for glass thicknesses from 8 to 31.52 mm, for other thicknesses please consult us.

It is important to provide the following information with each request: the glass composition (ex.: 10 mm monolithic, 8.8.4 laminated, 8.8.2-12-10 insulating) / the length and diameter of the threaded axle if not standard dimensions (M14, 65 mm) / the reference of the spider to be used as support, or the thickness of an existing support for the delivery of the spacer.

R 1001LC

## Mechanical performance

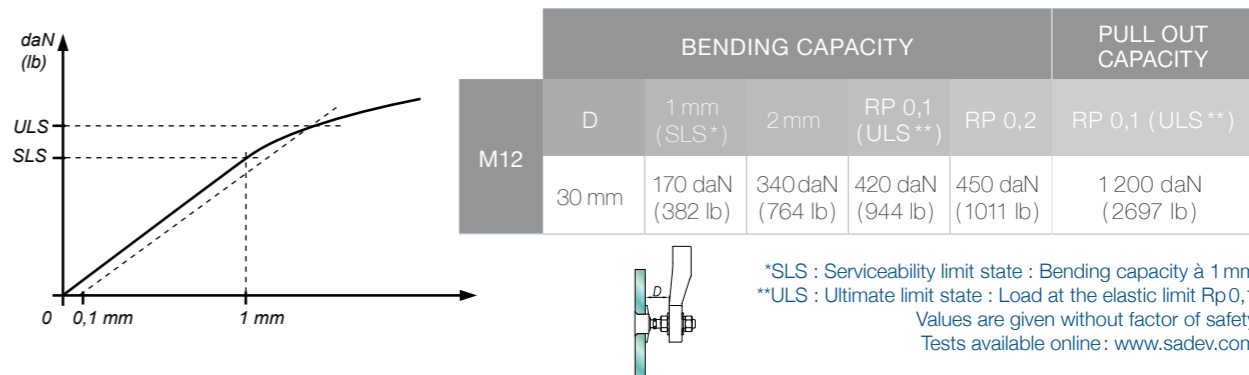

## Components

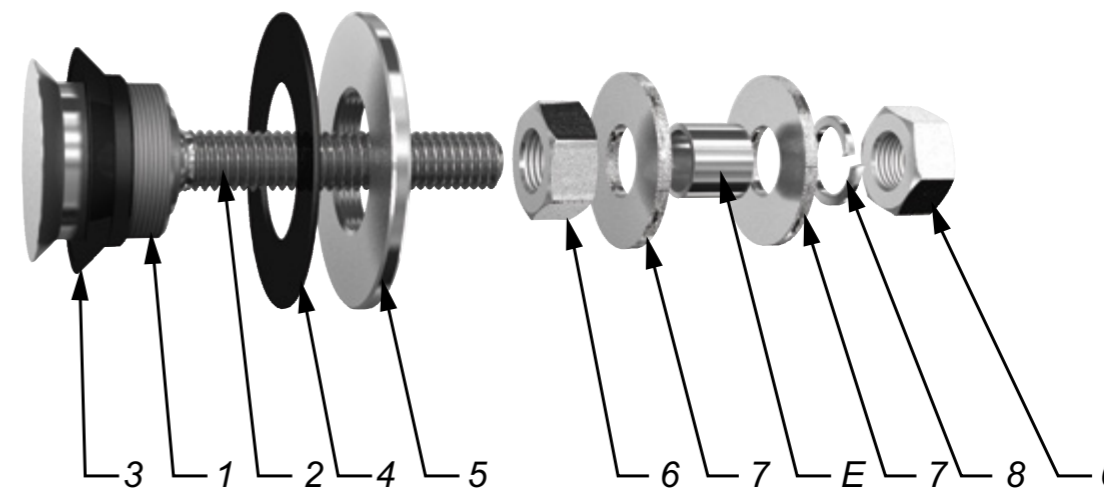

MARK	QUANTITY	DESIGNATION	MATERIAL
1	1	Swivel body	X2 Cr Ni Mo 17.12.2 as per EN 10088-3
2	1	Threaded Axle	X4 Cr Ni Mo 16.5.1 as per EN 10088-3
3	1	Glass hole grommet	Polyacétal noir / polyéthylène noir
4	1	Contact washer	Polyacétal noir / polyéthylène noir
5	1	Glass nut Ø50	X2 Cr Ni Mo 17.12.2 as per EN 10088-3
6	2	Nut DIN 934	A4
7	2	Washer	A4
8	1	Lock washer DIN127	A4

## Suggested mounting instruction

Insert parts N° 1/2 and 3 into the glass hole.  
Mount the second contact washer N° 4 and glass nut N° 5 and tighten to 20Nm (15 ft-lb) for monolithic glass and 10Nm (7.5 ft-lb) for laminated glass using tools SADEV ref. 758-11-60.  
Mount nut N° 6 and washer N° 7.  
Insert the threaded axle into the support with spacer E (available on request), see technical page. Adjust the depth. Mount washer N° 7, lock washer N° 8, and nut N° 9 and tighten to 60Nm (45 ft-lb) using a 19mm wrench.

SADEV recommends using thread locking compound whenever possible.